



Promote and enable the safe, effective use of powered access worldwide



THE SAFE USE OF MEWPS IN THE VICINITY OF POWER LINES



CONTENTS

1.0	INTRODUCTION	3
2.0	SCOPE	3
3.0	TERMS AND DEFINITIONS	4
4.0	WHO SHOULD READ THIS GUIDANCE?	4
5.0	POWER LINES AND THE RISK OF ELECTROCUTION AND ELECTRIC SHOCKS	6
6.0	ACCIDENT DATA	6
6.1	ACCIDENT DATA STATISTICS	7
7.0	PLANNING FOR WORK NEAR POWER LINES	8
7.1	PLANNING FLOWCHART	9
8.0	RISK ASSESSMENT	10
8.1	WHAT ARE THE HAZARDS?	10
8.2	ASSESSING THE RISK	10
8.3	RISK-CONTROL MEASURES	11
8.4	TRAINING AND FAMILIARISATION	11
9.0	REGIONAL ELECTRICAL INFRASTRUCTURE	12
9.1	MINIMUM APPROACH DISTANCES	13
10.0	EMERGENCY PROCEDURES	13
10.1	WHAT TO DO IF A PERSON HAS MADE CONTACT WITH A POWER LINE OR RECEIVED AN ELECTRIC SHOCK	13
10.2	TOUCH AND STEP POTENTIAL	14
11.0	TYPICAL SIGNAGE FOR POWER LINES AROUND THE WORLD	15
APPENDIX		16
	INSULATED AERIAL DEVICES (IADs)	16
	INSPECTION AND MAINTENANCE (INSULATED EQUIPMENT)	16
	ELECTRICAL PERIODICAL TESTING OF IADs	16
	REFERENCE MATERIAL	17
	INDUSTRY INNOVATIONS	17
HOW TO REPORT		18
ABOUT IPAF		19

NOTE: While every care has been taken to ensure the accuracy of the material contained within this guidance, no liability is accepted by the authors in respect of the information given. Compliance with this guidance does not give automatic assurance of compliance with legislative requirements. It is the duty holder's responsibility to ensure they comply with the legal requirements relevant to safe work equipment

Promote and enable the safe, effective use of powered access worldwide

1.0 INTRODUCTION

The International Powered Access Federation (IPAF) collates incident reports received from around the world, from companies, individuals and IPAF members who share their experiences to allow others to work more safely. By analysing the data, it is evident incidents involving electrocutions and electric shocks have notably increased from 2015 to 2021 but incidents have reduced in 2022, while the standout statistic is that reported incidents of electrocution are nearly always fatal.

Working in the vicinity of energised power lines can expose workers to health and safety risks including death by electrocution or electric shock.

If a Mobile Elevating Work Platform (MEWP) or its occupant(s) contacts energised power lines it can cause instant death, electric shock or other injuries caused directly or indirectly by electricity. Electrocution or electric shock can also occur by arcing or flashover from power lines. This can happen when exclusion zones are breached causing arcing to occur, the risk of arcing increases as the power line voltage increases.

We generally think of power lines being overhead and, for the large part they are. However, accident data indicates that often they can sometimes be beneath, for example,

if we are working above the power line or to the side of it. Working among dense vegetation/trees can often hide or obscure power lines.

Workplace safety culture and behaviour can play a big part in reducing the number of incidents. Ignorance or lack of awareness can lead to complacency and potential exposures, which in turn increase the risk of incidents occurring from contact or arcing with power lines.

2.0 SCOPE

This guidance is intended to:

- Provide information for those who plan and manage MEWP operations.
- Provide information on the main causes of electrocutions with power lines.
- Raise awareness of the hazards and risks involved in working in close proximity to power lines.
- Provide information on the industry sectors where electrocutions and electric shocks occur.
- Identify risk control measures and Safe System of Work (SSoW) to implement and reduce the number of incidents occurring.
- Provide general global guidance for those who undertake tasks to prevent incidents occurring.



3.0 TERMS AND DEFINITIONS

For the purpose of this document the following terms and definitions apply:

- **COMPETENT PERSON:** A person having sufficient professional or technical training, knowledge, actual practical experience, and authority to enable them to carry out their assigned duties at the level of responsibility allocated to them.
- **DELIVERY DRIVER:** A person who delivers and collects MEWPs from sites.
- **ENERGY SUPPLY AUTHORITY (ESA)** (main contractor).
- **IAD:** Insulated aerial device – offers protection against electric shock. They are designed so that key operating parts are covered in non-conductive protective materials.
- **MAD:** Minimum approach distance (MAD) also referred to as an exclusion zone. This will be referred to in the guidance but must be reflected in the ESA guidance provided in your own country.
- **MEWP:** Mobile elevating work platform.
- **MEWP OPERATOR:** A person directly using the MEWP controls from the work platform or the base.
- **OWNER:** Company, firm or person owning the MEWP, including those hiring it out to a User.
- **PPE:** Personal protective equipment.
- **PFPE:** Personal fall protective equipment – including fall arrest or restraint.
- **SSoW*:** Safe system of work, also referred to as SWMS – Safe-work method statement.
- **BANKSMAN, MARSHAL OR SPOTTER:** A safety observer. who has undergone specific training and is competent for the sole task of observing and warning the MEWP operator if a MEWP is nearing an exclusion zone.

- **STAND-OFF DISTANCE:** The safe positioning of a MEWP without compromising the absolute minimum exclusion zone.
- **USER:** A person or organisation that controls the planning, management, and use of the MEWP and is responsible for ensuring the MEWP is kept in a safe working condition.

NOTE 1: This can include the person responsible for the site, principal contractor, or sub-contractor.

NOTE 2: This is not necessarily the same as the operator.

4.0 WHO SHOULD READ THIS GUIDANCE?

Employer or User: Person or organisation that has control of the planning, management, and use of the MEWP on site and is responsible for ensuring the MEWP is kept in a safe working condition.

The energy supply authority (ESA) contractor: Responsible for completion of the work. The sub-contractor also has a duty of care to their employees, other sub-contractors, and members of the public. Sub-contractors can be electrical utility companies and include arboricultural/tree-care companies.

The energy supply authority (ESA) (main contractor): Commissioning work near to areas and locations where there are power lines. The energy supply authority has a duty of care for the electricity network and performs and organises service, maintenance and repair work on power lines and associated infrastructure.

The MEWP operator: The MEWP operator is a person using the MEWP from the work platform or the base/ground controls. They may be employed or self-employed.



Responsibilities for safety.

Working in close proximity to power lines always need careful planning regardless of the nature and duration of the task. Table 1 below identifies the responsibilities and the principal duties of the key stakeholders, it is recommended that all listed duty holders (with the exception of the general public) should read this guidance.

Duty holder	Responsibility	Principal duties
Client	Choose a suitable and competent contractor	<ul style="list-style-type: none"> • Check ability to do the work safely. • Check evidence of training. • Check using competent staff. • Check appropriate insurances are in place. • Ask for reference.
Employer/ Contractor (User)	Organise and manage the task to ensure it is performed safely	<ul style="list-style-type: none"> • Determine the work at height task and means of access. • MEWP selection. • Planning, risk assessment to develop SSoW* • Operator competence. • Correct PPE and PFPE. • Clear instructions. • Management of task. • Supervision and emergency planning.
Operator	Complete the task in a safe manner	<ul style="list-style-type: none"> • Understand the risks with the task to be performed. • Understand and follow preventative measures in place ie SSoW. • Understand emergency procedures and rescue plan. • Use the correct PPE and PFPE. • Complete pre-use checks. • Undertake a dynamic SB Work Place inspection and verify or amend the SSoW. • Have a constant awareness of surroundings. • Be aware and adapt to potential changes in surroundings and environment. • Have the authority to stop work if the task is deemed unsafe.
Delivery driver	Carry out delivery and collection of MEWPs on site in a safe manner	<ul style="list-style-type: none"> • Complete risk assessment before delivery and collection of MEWPs on site. • Be aware of the risk of electrocution and electric shocks from power lines above and below ground. • Use the correct PFPE and PPE. • Have a constant awareness of surroundings while undertaking load and unload activities. Never position vehicle beneath overhead power lines or inside MAD. • Be aware of the height of the load on the trailer and the approach distance when passing beneath power lines.
General public	Moral duty of care	<ul style="list-style-type: none"> • Raise concerns if an unsafe act or an unsafe condition is observed. • Keep a safe distance from the work area and adhere to signage and specific site instructions.

Table 1 – Key duty holders, their responsibilities, and principal duties.

Credit: William Currie



5.0 POWER LINES AND THE RISK OF ELECTROCUTION AND ELECTRIC SHOCKS

Electrocution and electric shocks are often considered to be the same thing, in fact they are not, so what is the difference?

Electrocution:

Means a person has died because of contact with electricity; this can be caused by:

- Accidental contact with a power line.
- Arcing or flashover with a power line.

Electric shock can occur:

- When a person comes into contact with an electrical energy source. Electrical energy flows through a portion of the body causing a shock.
- Exposure to electrical energy may result in no injury at all or may result in devastating damage or death.

Victims of electric shocks often suffer life-changing injuries such as amputation, severe burns, brain and other nerve damage.

Arcing or flashover

A flashover is a high-voltage spark or arcing that passes through the air between an electrical conductor and a grounded conductive object. Potential flashover distance is the distance that an arc can travel through free air at a given voltage and environmental conditions. Conditions such as high humidity cause the flashover distance to increase, as there is more moisture in the air to allow electricity to conduct.

6.0 ACCIDENT DATA

IPAF global accident data informs us that non-electrical workers, ie those who are not directly employed or subcontracted by energy supply companies, are more frequently involved in more injuries or deaths from electrocution. The data also informs IPAF that those who work in arboriculture, construction, and electrical work are most at risk. A lack of planning is often a major cause of non-electrical trade incidents.

Major injuries can be life-changing and the impact can be felt not only by the person who has received an injury but by family and friends alike. Effects from major injuries can also include depression, anxiety, post-traumatic stress disorder (PTSD) and other mental health problems.

Failure to identify power lines can be fatal, while failure to understand and respect the risk of electrocution from power lines also puts workers at risk. Electricity is invisible, when contact or arcing occurs, temperatures can be hotter than the sun!

- ➔ **Never take short cuts!**
- ➔ **If something isn't right – stop!**
- ➔ **Make sure everyone is trained – managers, supervisors, operators, spotters.**
- ➔ **Always have a healthy respect for power lines and the risk of electrocution or shock.**

IF YOUR MEWP IS IN CONTACT WITH A POWER LINE, FOLLOW THESE STEPS:



STAY
REMAIN IN THE MEWP PLATFORM



CALL
CALL THE EMERGENCY SERVICES



WAIT
WAIT IN THE PLATFORM UNTIL HELP ARRIVES

6.1 ACCIDENT DATA STATISTICS

From 2012-2021 accident reports, IPAF identified that the top three industries for electrocutions and electric shocks globally were:



Arboriculture



Construction



Electrical

In this period, we received 169 reports from 12 countries, with 179 people involved and 129 fatalities over the 10-year period.

Vehicle-mounted (1b) MEWPs are the most common type of MEWP to be used for working in and around power lines, mainly owing to the ease of use of this type of equipment and the fact most distribution lines are normally accessible from roads.

IPAF has not conducted investigations into deaths or serious injuries resulting from electrocutions or shocks; these investigations are normally carried out by enforcing authorities. Industry experts inform us that incidents normally occur when there is a lack of planning, this means:

- Failure to identify the presence of power lines within the work area.
- Incorrect MEWP selection (insulated or non-insulated).
- Untrained operators.
- Lack of machine-specific familiarisation.

The areas where most incidents occurred were in public areas, on or adjacent to highways, followed by construction sites.

When we look at the MEWP rental sector specifically on electrocutions and electric shocks (2012-21) there have been 16 reports entered from three countries. There were 15 people involved and nine fatalities.

The number of reports from the period 2019-21 show shown an increase in the number of incidents involving electrocutions and electric shocks.

The number of reports is up 33% in this period – this could be down to better reporting as people understand that we can learn from the data we receive. IPAF received reports from nine countries in this period, which is up by 12.5%. There were 106 people involved in accidents, which is up by 68.3%, and the number of fatalities was 72, an increase of 50%.

IPAF continues to encourage accident reporting globally; concise accident data enables IPAF to update training material and produce specific guidance to reduce the number of fatalities and serious injuries globally.

People involved by machine category

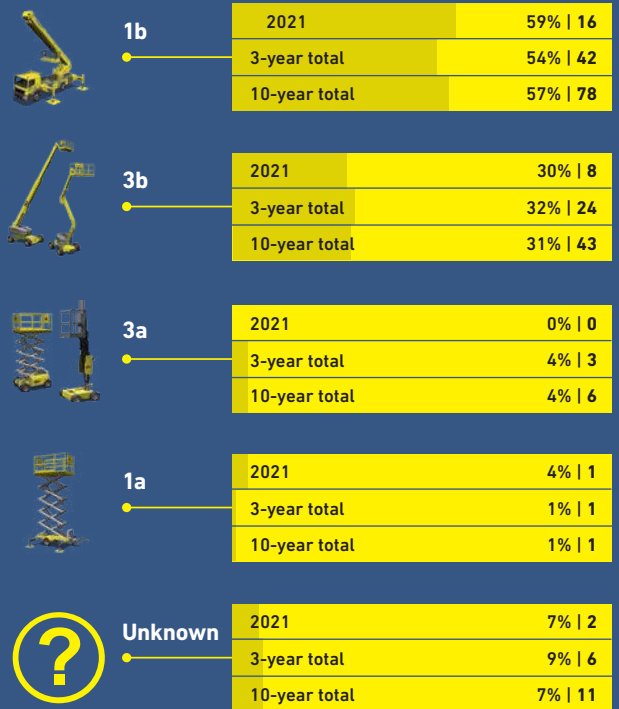

Total electrical trends 10-year period

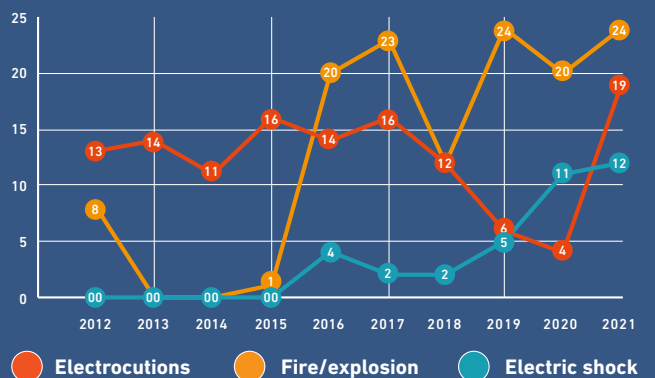

Lost time incidents by location

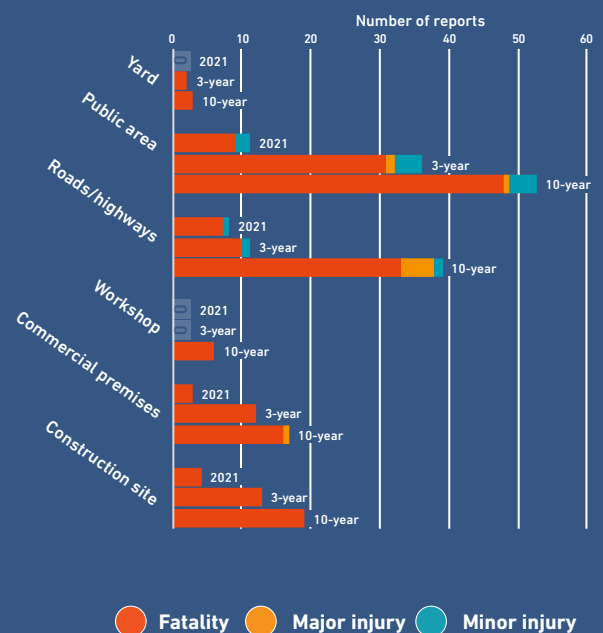

7.0 PLANNING FOR WORK NEAR POWER LINES

Working in close proximity to live power lines is an everyday occurrence for some industry sectors, as infrastructure must be expanded, modified and maintained in line with changing domestic and commercial needs or requirements.

Most injuries or deaths from electrocutions can be traced back to inadequate or poor planning. The planning stage of any work that involves working near to electrical infrastructure must be completed by a competent person. The plan must be communicated directly with, and understood by, all persons involved in the task.

Incidents involving non-electrical workers are often down to failure to identify power lines prior to commencing of work, leading to a failure to take adequate precautions.

Before operating a MEWP in the vicinity of power lines, and outside any exclusion zone, consultation regarding the work and the related risks should occur between the User and the MEWP operator.

Any work required on the electrical network infrastructure is normally organised and arranged through the government main contractor in that country, region, or state. We refer to this in this guidance as the energy supply authority (ESA). The ESA is responsible for building, maintaining, and operating the electricity supply network. The government main contractor may choose to sub-contract any maintenance or repair work to an authorised sub-contractor.

There are two options for working near power lines:

- (a)** Have the power lines isolated; or
- (b)** stay outside the exclusion zones.

If power lines are to be de-energised and isolated, arrangements should be made with the ESA as early as possible when planning and scoping the work. The de-energising process can take some time and depending on the circumstances, may delay the work. Where power lines have been de-energised, confirmation should be received from the person in control of the power line before work commences.

Planning may include:

- Risk assessments and method statements;
- location of the work to be carried out;
- pictures of the task and the surrounding landscape;
- access and egress to site;
- consideration of specialist vehicles and equipment;
- number of trained staff involved;
- spotter/banksman;
- communication system between the operator and the spotter;
- emergency procedures and rescue plan;
- engineering control or warning measures such as devices connected to equipment that detects electricity.

Planning is critical to ensuring the task is managed and performed safely. Continual observation when operating a MEWP is critical for platform occupant safety – many lives could potentially have been saved if people had looked out and around for power lines before elevating the MEWP.



7.1 PLANNING FLOWCHART Planning for MEWP operations outdoors



CARRYING OUT MEWP OPERATIONS OUTDOORS

LOOK OUT, LOOK UP!

Key

- ESA:** Energy Supply Authority
- MAD:** Minimum Approach Distance
- SSoW:** Safe system of work, also referred to as SWMS Safe-work method statement.

Have you identified power lines in your area?

No

Yes

Are you far enough away so as not to need to contact the ESA?

Yes

No

Have you contacted the ESA to identify if the power lines are energised?

No

Yes

Have you received confirmation from ESA that power lines are de-energised?

Yes

No

Is your work outside the MAD?

No

Yes

Perform risk assessment and SWMS

Implement control measures from risk assessment. All work must be outside the MAD

Records kept

Commence work

Do not start work: Refer to site manager or supervisor for further instructions



8.0 RISK ASSESSMENT

8.1 WHAT ARE THE HAZARDS?

All potential hazards must be identified, to determine anything that may cause harm or injury. Assess the environment and select the correct MEWP to be used – ensure there is no likelihood of the equipment encroaching into an unsafe area where there is a risk of electrical arcing or flashover. Always consult with the ESA to obtain the minimum approach distance required for safe operation. Remember to allow for the expected sagging distance of the line based on use or temperature.

8.2 ASSESSING THE RISK

Where possible, refer to any previous work carried out in the location, as this may have method statements and risk assessments that could form the basis of your own plan. However, you need to consider that equipment, personnel, and the environment may have changed. The assessment can help determine what action you need to take to eliminate or control the risk and how urgently the action needs to be taken.



EXAMPLES OF RISK FACTORS TO CONSIDER:



Activity

- The type of work required and the frequency of work tasks.
- The provision of site personnel.
- The qualifications, competency, skill, and experience of people doing the work.
- The loading and unloading of MEWPs and other machinery must be done well away from any power lines.



Environment

- Assess tree cover and vegetation, as well as environmental conditions, eg atmospheric conditions, storm activity, heavy rain, temperature, hail, and lightning along with other relevant site conditions, eg wind velocity, terrain, ground surface and condition and vehicular traffic.



Equipment

- Correct MEWP selection – consider the MEWP working envelope, dimensions and operating characteristics, and Correct MEWP selection.
- The setting up and de-rigging processes of the MEWP and equipment.



Location

- The location, height, arrangement, and visibility of power lines and supporting structures, eg poles, towers and stay wires the voltage of power lines and exposed energised parts and whether they are insulated or bare.
- The possible sway and sag of power lines.
- Vehicles entering work areas should be warned about the maximum allowable height. No part of the vehicle should exceed the specified approach distance, this includes vertical exhausts, flashing beacons and radio aerials and other accessories.
- The distance between the power line and the ground may increase or decrease, for example when constructing a road or level bank beneath power lines or where the ground level is raised during the work. The distance between the vehicle should be continually reassessed to ensure the relevant approach distances are being maintained.



8.3 RISK-CONTROL MEASURES

Always try and eliminate the hazard with a risk-control method. The person carrying out the risk assessment must be trained, competent and have suitable knowledge experience, to carry out this task.

An effective way to eliminate the electrical hazard and reduce the risk of direct contact or an arcing from power lines is to prevent people, plant, equipment, and materials from coming close enough to a potentially energised power line.

Consider:

- De-energising the electric line, and isolating and earthing the line for the duration of the work, or
- Having the power line routed away from the work area.
- Identify and respect the minimum approach distance.
- Allocating a nominated spotter to the task.

8.4 TRAINING AND FAMILIARISATION

Specific electrical infrastructure training is critical for staff who will be working in the vicinity of power lines, this includes staff who may not be operating MEWPs such as spotters or banksmen.

Spotters must be able to communicate and manage risks and hazards, including maintaining minimum approach distances. A spotter should not perform any other tasks while performing the spotter function. They must also be aware of the MEWP operating envelope so that no part of the MEWP enters the exclusion zone. Spotters must also be familiarised with the emergency lowering procedures specific to the MEWP.

Familiarisations are required on any MEWP that is significantly different in weight, height, length, or complexity to the MEWP on which training took place. For insulated MEWPs there are additional familiarisation requirements. Please see **F1 – IPAF familiarisation in Appendix.**

9.0 REGIONAL ELECTRICAL INFRASTRUCTURE

Transmission lines

This is a power line used in electrical power transmission and distribution to transmit electrical energy across large distances. It consists of one or more uninsulated electrical cables suspended by towers or poles. Multiple lines can carry different voltages.

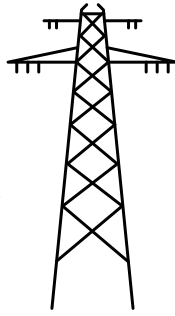

Distribution lines

A distribution power line is the final stage of the electrical grid which distributes electricity to homes, businesses and other end users. Distribution power lines deliver the electrical power to all users supplied by the grid and, and once delivered, it also reduces power to safe customer-usable levels.

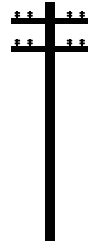

Some distribution lines are fitted with sheathing, refer to Figure 1. This sheathing does not insulate the power line, it only prevents damage occurring to the power line. MAD must be adhered to, as arcing or contact with the power line can result in electric shocks or electrocution.



Figure 1

Electrical energy is created and distributed through a grid to domestic and commercial premises. The way electricity is delivered will largely depend on the country or region you live in. In some countries, electricity is delivered overground by transmission and distribution lines and in other countries it can be distributed underground.

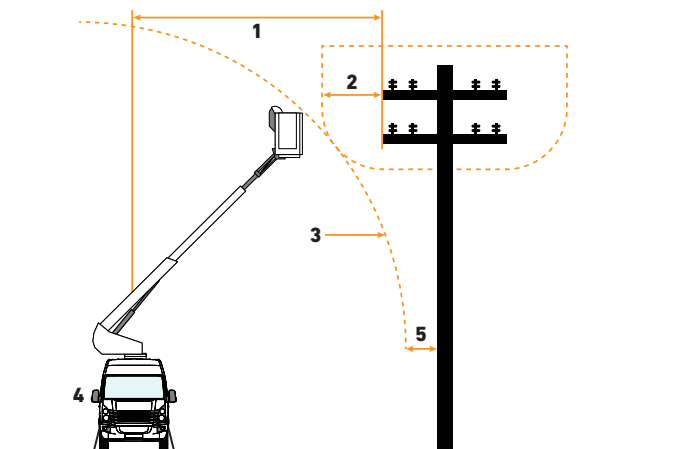

Figure 3

1. Safe stand-off distance
2. Minimum approach distance
3. Minimum operating reach
4. MEWP positioned perpendicular to the power line where possible
5. Minimum 600mm/2ft from any point of the pole or pylon

Electrical voltage can be supplied in high or low voltages. For example, in the US there are more high-voltage power lines than low-voltage power lines and outside each home there will be a transformer that reduces the voltage from high to low.

It is essential that duty holders are aware of the presence of power lines and to consider in the risk assessment. However, the MEWP operator should also always check for the presence of power lines in the proximity of the work area, including travel routes, setting up, and before starting work. Remember, when elevated at height power lines can in some cases be beneath the platform.

Where power lines are identified, you must always assume they are live unless informed otherwise by the ESA and apply IPAFs 30ft (9m)/50ft (15m) rule for the safe stand-off distance from power lines.

Get more information in our resources library

[VISIT OUR RESOURCES LIBRARY](#)

NOTE: IPAFs recommended set-up distances meet and exceed those specified in many countries/regions. Should the operator need to work any closer to power lines, they should seek expert advice from the ESA and implement additional safety precautions as outlined below to ensure the minimum approach distances (MAD) are never compromised. MAD from power lines may differ depending on the region you are in; it's critical you consult with the ESA for the safe stand-off distances of MEWPs from power lines. MEWP operators must also refer to the safety decals and operator's manuals for the minimum approach distances.

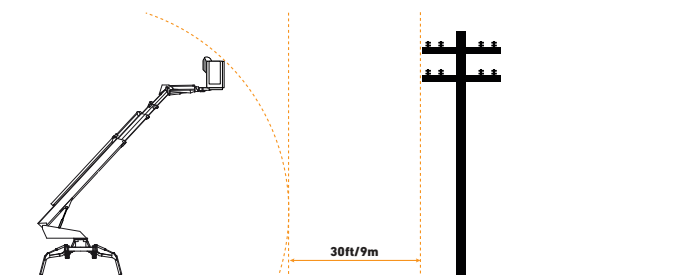

30 feet/9 metres + fully extended boom on distribution lines

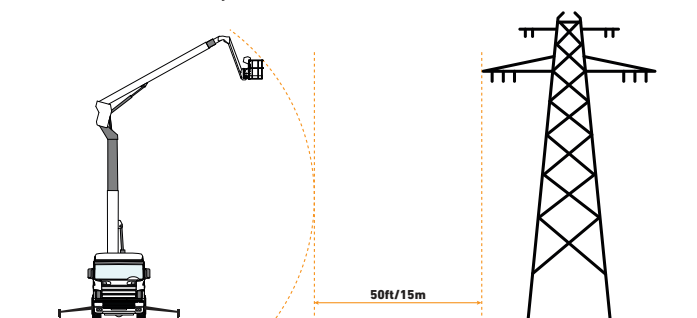

50 feet/15 metres + fully extended boom on transmission lines

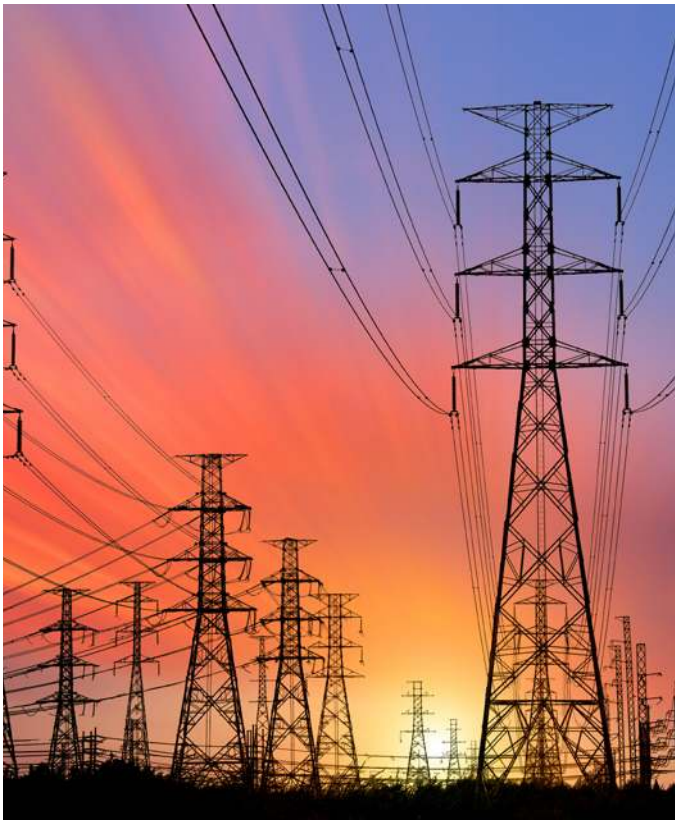

10.0 EMERGENCY PROCEDURES

10.1 WHAT TO DO IF A PERSON HAS MADE CONTACT WITH A POWER LINE OR RECEIVED AN ELECTRIC SHOCK

If someone has been electrocuted by the arcing of electricity or contact with a power line you must immediately call the emergency services and have the power turned off.

9.1 MINIMUM APPROACH DISTANCES

The minimum approach distance (MAD) is the proscribed area around live electrical power lines. An operator must not operate a MEWP where any part of the MEWP could enter the MAD. The specific distances must be obtained from the electricity supply authority. MAD can also vary according to the voltage, the type of power lines, and whether the person is untrained, trained or authorised, Figure 3.

Several factors must be considered when implementing systems to maintain the MAD around power lines. These include:

- Identifying the minimum clearance/approach distance from the closest part of the MEWP to the nearest power line/conductor.
- Allowing for sway and sag of the power lines, especially in windy conditions.
- The temperature and humidity of the area.
- Ensuring all persons operating plant and vehicles stay outside the minimum approach distance at all times.
- Provision of a spotter to monitor the work.

MAD and work zones will vary for people, plant and vehicles depending on the voltage of the power lines, whether the electric power lines are insulated or non-insulated. You must contact the energy supply authority in the region you are in to determine the MAD.

Electrocutions have occurred when delivery drivers from the MEWP rental company have driven their loaded vehicles under live power lines and made contact with live power lines.



DO NOT APPROACH A MEWP THAT HAS MADE CONTACT WITH LIVE POWER LINES. THE MEWP SHOULD BE DEEMED LIVE UNTIL CONFIRMED SAFE BY THE ESA.



ELECTRICAL POWER CANNOT BE SEEN: YOU WON'T KNOW WHETHER OR NOT THE POWER LINE HAS BEEN ISOLATED.



NEVER TOUCH A PERSON WHO APPEARS TO BE HAVING AN ELECTRIC SHOCK, AS YOU COULD ALSO RECEIVE A SHOCK.



**STAY SAFE – STAY AWAY –
WARN OTHERS TO STAY AWAY**

If someone has received an electric shock from a power line but is no longer in contact with the electrical source you should immediately call the emergency services, and if necessary, administer first aid.

10.2 TOUCH AND STEP POTENTIAL

Touch potential

If a MEWP makes contact with a power line, the MEWP or parts of it could become live, it is wrong to assume that rubber tyres or tracks will insulate the MEWP. If a person touches any part of the MEWP at ground level they could be electrocuted or receive an electric shock, which can cause death or serious injury.

The reason for this is that the machine is live, and the electricity is looking for a path (or direction) to earth; if you touch the machine, you will potentially become the path to earth. This is known as the touch potential.

Step potential

When a MEWP is in contact with live power lines it too can become live, it could also mean the area and ground around the base of the MEWP also becomes live. The voltage will be at its highest at the source but will reduce in voltage the further from the source it gets. This effect is called step potential.

Procedure to follow for touch and step potential:

If a MEWP has come in contact with power lines, you must not in any circumstances touch any part of the MEWP. You should immediately call the emergency services and arrange for the power to be isolated.

If you are on the ground and in the close proximity to the MEWP that has touched a live power line you must move away by shuffling your feet. You should not lift your feet as you walk, as the difference in voltage can pass through your body and cause death or serious injury.



Step potential



Touch potential



Figure 2 Image showing scenario where person could be at risk of electrocution or electric shock.

11.0 TYPICAL SIGNAGE FOR POWER LINES AROUND THE WORLD

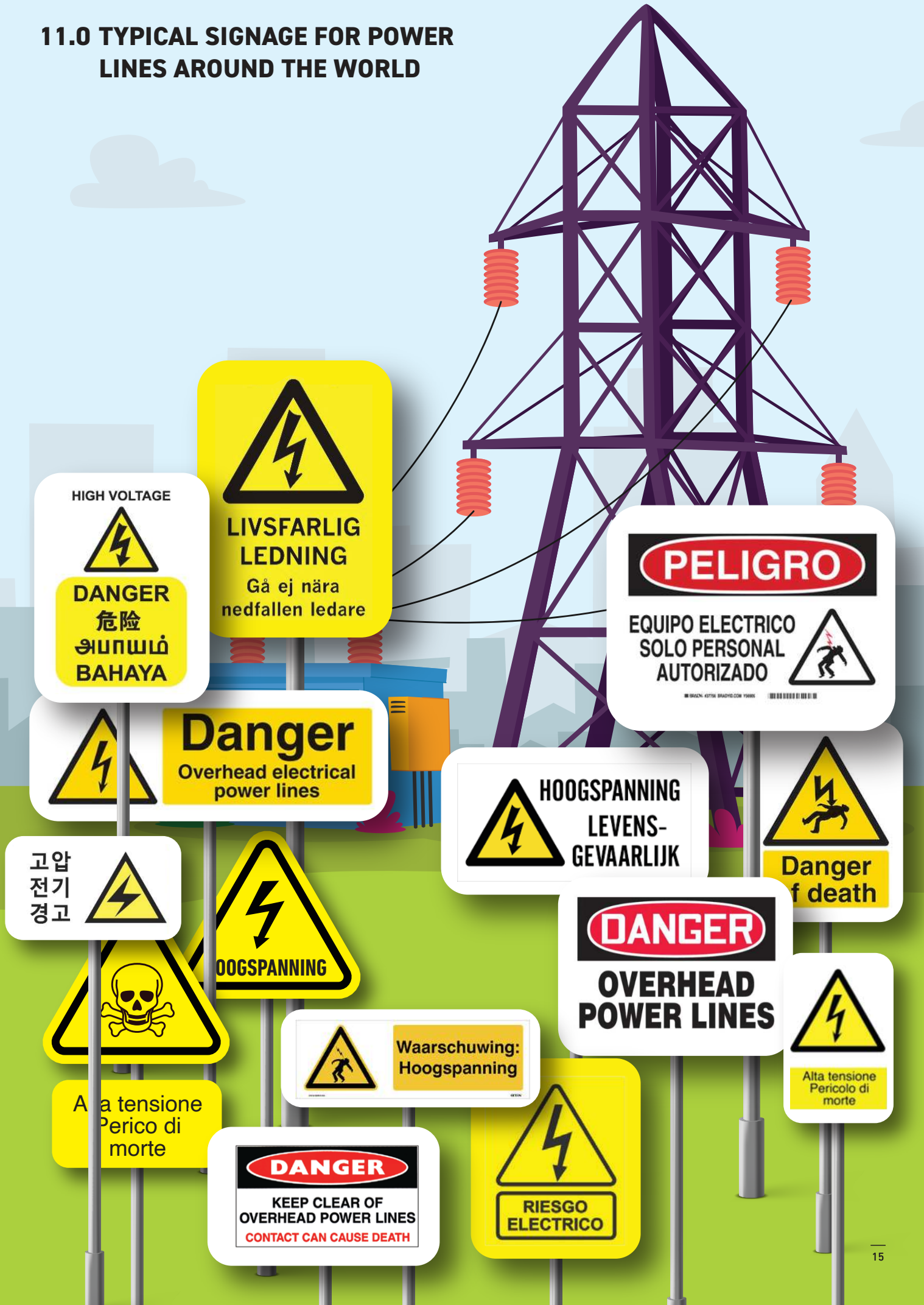

APPENDIX

- I. INSULATED AERIAL DEVICES (IADs) 16**
 - Inspection and maintenance – insulated equipment (IADs) 16
 - Electrical periodical testing of IADs. 16
- II. REFERENCE MATERIAL 17**
 - IPAF Familiarisation Statement (F1) 17
 - Safe Use of MEWPs in Public Areas Document reference TE-1095-0222-1 17
 - Traffic management general principles 17
 - Toolbox Talks. 17
 - Andy Access posters. 17
- III. INDUSTRY INNOVATIONS 17**
- IV. ACCIDENT REPORTING 18**
- V. ABOUT IPAF 19**

INSULATED AERIAL DEVICES (IADs)

MEWPs can be insulated or non-insulated. The site assessment you make on what type of MEWP you intend to use should be based on your risk assessment. If you are working in the vicinity of power lines, you should consider the use of IADs as this will offer more protection and minimise the risk of electrocution to the operator if there is contact or arcing of electricity.

The purpose of an insulated MEWP is to minimise the risk of electrocution to personnel. Insulated MEWPs can be separated into two categories – high voltage and low voltage. The electrical rating for the MEWP should be clearly identified on the equipment, this is normally found on a data plate and on decals that will be affixed to the boom structure.

Insulated MEWPs that work in high-voltage areas must be fitted with insulating boom insert(s) as well as have an insulated platform and they are sometimes fitted with a liner that offers additional protection. See image, *right*, for reference.

Section ‘A’ is the upper boom insulation that is designed to protect the occupants.

Section ‘B’ is the insulated section in the lower boom that provides chassis protection.

The bucket/platform is not considered to be an insulated component except when fitted with a liner.

INSPECTION AND MAINTENANCE (INSULATED EQUIPMENT)

Insulated aerial devices (IADs) can be more complex than standard non-insulated equipment. Familiarisations on IADs must cover:

- Electrical test certificate currency (in date);
- boom insulation rating;
- the understanding, and legibility of colour coding of decals for insulated sections of boom sections;
- platform and ground controls;
- operation of safety devices that are fitted;
- power take-off (PTO) if fitted;
- hydraulic accumulator (if fitted);
- condition of fibreglass areas.
- the condition of any non-conductive items such as hydraulic hoses;
- emergency Descent Devices (EDDs) if fitted;
- anchorage point locations for personal fall protection equipment (PFPE);
- condition of platform/bucket liners (if fitted);
- set up and de-rigging of stabilisation system;
- demonstration of spring lock-outs or torsion bars (if fitted);
- outrigger pads;
- Earthing equipment, attachment points and procedures.

ELECTRICAL PERIODICAL TESTING OF IADs

Dielectric testing is an evaluation process performed by applying a voltage to an electrical component that exceeds its normal operating voltage. The purpose of the test is to determine if a component’s insulation is adequate to protect the user from electric shock.

It is an important tool to safely plan and/or perform work around the electricity network.





REFERENCE MATERIAL

- ➔ **Andy Access (AA) safety posters**
- ➔ **IPAF Safety Advice – No Second Chances**
- ➔ **IPAF Familiarisation Statement (F1)**
- ➔ **IPAF Toolbox Talks (TBT)**
- ➔ **IPAF Safe Use of MEWPs in Public Areas**
- ➔ **Touch & Step Potential video**

INDUSTRY INNOVATIONS

Some MEWPs (insulated and non-insulated) can be fitted with high-voltage protection systems. These systems can alert the operator if the MEWP platform is in proximity to an electrical source.

These systems must be maintained as per the OEM requirements, devices that are faulty or damaged can endanger the operator by allowing the MEWP to be too close to power lines.

IPAF does not promote or endorse any product. It should be noted that no one particular device or system will prevent electrocution in all known circumstances when operating a MEWP.

The operator and nominated emergency rescue personnel should be made familiar with the operation of any additional voltage-protection system including functionality, how it is triggered, operated and reset.

Once fitted, any voltage-protection system should be included in the MEWP pre-use inspection regime.

When selecting a device or system to address a single hazard, consideration should be given to the potential for significantly increasing other possible hazards.

There are various systems available to purchase, below are some examples:

- ➔ **GoUpSafely – Aerial High Voltage Protection System**
- ➔ **MEWP Shield Boom – Overhead Crush Protection + HV detection**
- ➔ **The Wire-Watcher Company**
- ➔ **LiveLine Defender™ Sterling Agencies – Are you working safely at height?**
- ➔ **The lookupandlive.com app (IOS and Android) that has been developed by Energy Queensland (Australia only).**

It is an important tool to safely plan and/or perform work around the electricity network.

Note: Lookupandlive.com app is only available in Australia.



HOW TO REPORT

www.ipafaccidentreporting.org

IPAF and its members analyse anonymised data on incidents involving powered access to identify areas of risk and common trends, which informs guidance, training and safety campaigns. We aim to increase our understanding of working practices and reduce incidents in every country. Reporting is not restricted to IPAF members; any person or organisation can report an incident. In 2021, IPAF launched ePAL, a mobile app for operators and supervisors, which enables quick on-the-spot reporting direct to the IPAF portal of all incidents – including near misses.

How to report

All accidents, incidents and near-misses can be reported quickly and easily at www.ipafaccidentreporting.org via desktop or laptop PCs, most web-enabled mobile devices, or through the IPAF ePAL app (www.ipaf.org/ePAL) for operators and supervisors. Please register first to report accidents on the database. Reports can also be made anonymously via the portal. Companies wishing to have multiple persons reporting accidents should appoint a nominated person (a senior person who will manage reporting). This nominated person should register first in the company name. Once registered, the nominated person will be able to give others access to report accidents and be able to track their accidents and manage their incident records. Information entered into the database will be kept confidential and will be used strictly for the purposes of analysis and improving safety.

What is reported

All reported incidents involving powered access are collated by IPAF. This includes incidents that result in death, injury or a person requiring first aid. It also includes near-miss incidents that didn't result in injury or damage to machines or structures, yet still represented a potentially dangerous situation for machine occupants or bystanders.

The machines

The report analyses incidents that occurred when using, delivering and maintaining Mobile Elevating Work Platforms (MEWPs). IPAF also collates incidents involving other machinery including Mast Climbing Work Platforms (MCWPs), all types of construction hoists and telehandlers.

Who can report?

Anyone involved in working at height can report an incident to the IPAF portal. The data presented in this report is based on information collected either directly reported via the IPAF portal; obtained by IPAF staff worldwide; using data from regulatory bodies; and through information collated from media reports. IPAF also now offers a special customisable dashboard for all members reporting, which enables them to benchmark their company's performance against regional, national and global data.

Confidentiality of data

The information provided to IPAF is confidential and private. Information that can identify a person or company involved in a reported incident is removed prior to analysis by IPAF and its committees, and thereafter remains redacted. IPAF has a privacy policy that can help you understand what information we collect, why we collect it, and how you can update, manage, export and delete your information. The full IPAF privacy policy can be found at www.ipaf.org/privacy

ABOUT IPAF

The International Powered Access Federation (IPAF) promotes the safe and effective use of powered access equipment worldwide in the widest sense – through providing technical advice and information; through influencing and interpreting legislation and standards; and through safety initiatives and its training program.

IPAF is a not-for-profit organisation owned by its members, which include manufacturers, rental companies, distributors, contractors, and users. IPAF has members in more than 80 countries, who represent the majority of the MEWP rental fleet and manufacturers worldwide. Visit www.ipaf.org for local office information.

Contact IPAF

Moss End Business Village
Crooklands
Cumbria LA7 7NU
United Kingdom

Tel: +44 (0)15395 66700
info@ipaf.org
www.ipaf.org

Become an IPAF member

By joining IPAF you are joining a global movement to ensure a safer and more productive powered access industry. Membership also brings a host of special services and benefits including access to the members' safety analysis dashboard. IPAF brings multiple benefits including the following:

- Global harmonisation with regional focus on standards development;
- Resources for technical experts;
- A wide range of products and technical guidance to assist MEWP users, supervisors and user meet their responsibilities;
- Opportunities to network and promote your company;
- A consensus voice for all industry stakeholders, large and small;
- Certified training program to ensure complete, consistent and compliant training.

For more information about becoming a member of IPAF visit www.ipaf.org/join

IPAF would like to thank the members of the working group below who helped in the development of this document:

Mark Keily of Sunbelt Rentals UK

Peter Wellspring of Bronto Skylift Australia / New Zealand

Glen Cook (Cookie) of Energy Queensland

TJ Lyons of Gilbane Construction

James Clare of Niftylift

Chris Wraith of Access Safety Management Ltd

IPAF Safety & Technical department

IPAF Communications & Membership department

In conjunction with

This guidance document was developed in conjunction with the IPAF International Safety Committee.



*Promoting the safe and effective
use of powered access worldwide*

Supplied by: